

# Hand & mechanical directional valves

ISO 4401 sizes 06, 10, 16 and 25

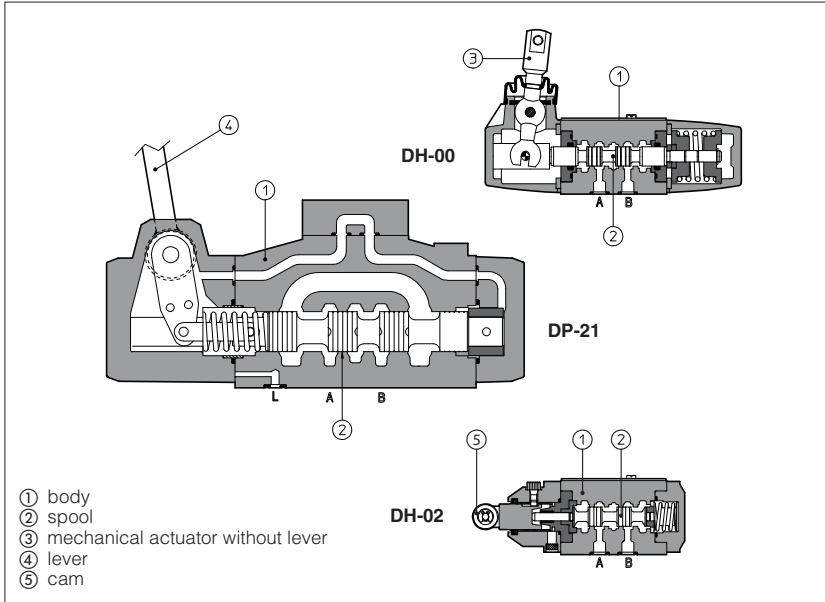

Hand & mechanical operated directional valves are spool type, three or four way, two or three position, designed to operate in oil hydraulic systems.  
Available versions:  
- mechanical actuator without lever;  
- hand-lever;  
- cam (only for size 06 and 10).

- DH-0 = ISO 4401 size 06 interface: flow up to 50 l/min.
- DK-10 (11) = ISO 4401 size 10 interface: flow up to 100 l/min.
- DK-12 = ISO 4401 size 10 interface: flow up to 140 l/min.
- DP-2 = ISO 4401 size 16 interface: flow up to 300 l/min.
- DP-3 = ISO 4401 size 25 interface: flow up to 650 l/min.

Max pressure:  
350 bar for DH-0, DP-2, DP-3  
315 bar for DK-1

## 1 MODEL CODE

<b>DH-0</b>	<b>1</b>	<b>1</b>	<b>3</b>	<b>/C</b>	<b>/A</b>	<b>**</b>	<b>/*</b>
<p>Directional control valve, size:  <b>DH-0</b> = 06  <b>DK-1</b> = 10  <b>DP-2</b> = 16  <b>DP-3</b> = 25</p> <p>Type of actuator:  <b>0</b> = mechanical, without lever  <b>1</b> = hand-lever  <b>2</b> = cam (only for DH-0 and DK-1)</p> <p>Valve configuration, see section 4  <b>0</b> = free, without springs  <b>1</b> = spring centered, without detent  <b>2</b> = return to internal position (lever toward extern)  <b>3</b> = return to external position (lever toward the valve)  <b>4</b> = 3 position, with detent  <b>5</b> = 2 external positions, with detent  <b>6</b> = centre plus external positions, with detent  <b>7</b> = return to external position from the centre position  <b>8</b> = return to the centre position from the external position</p>						<p>Synthetic fluids:  <b>WG</b> = water-glycol  <b>PE</b> = phosphate ester</p> <p>Series number</p>	
				<p>Options:  <b>/A</b> = actuator device mounted on side of port B                  Only for configuration 6, 7, 8, of hand-lever valves, see section 4 and 5 for hydraulic connections:  <b>/I</b> = in rest position the lever is inclined towards the valve body  <b>/E</b> = in rest position the lever is inclined in opposite side                  Only for DK-1:  <b>/Y</b> = external drain</p>			
				<p>Only for hand-lever valves:  <b>/C</b> = short hand - lever and reduced actuation force (only for DH-01)</p>			
				<p>Spool type, see section 5</p>			

## 2 HYDRAULIC CHARACTERISTICS

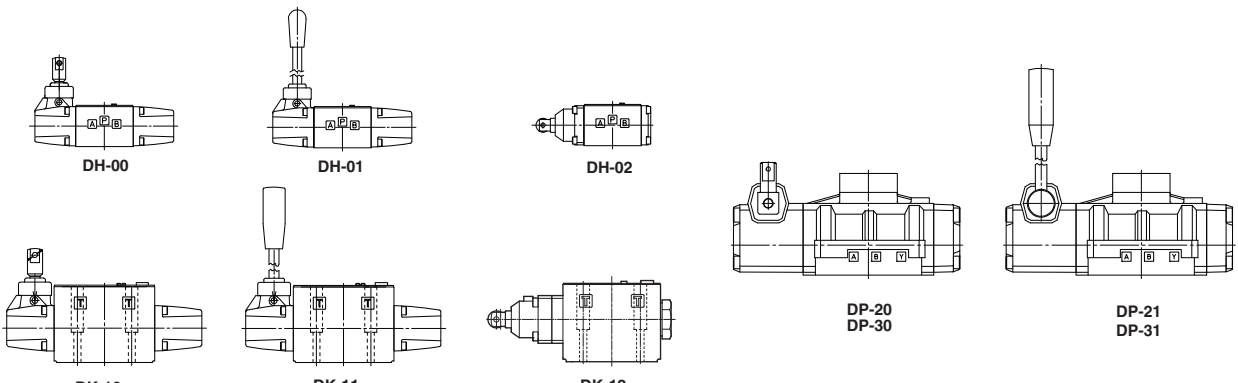









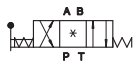

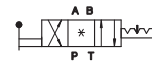
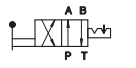
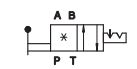
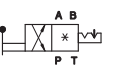
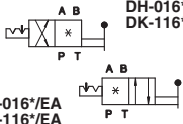
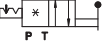
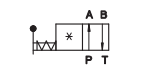
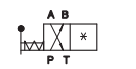
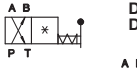
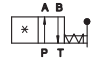



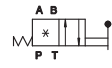

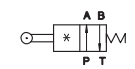
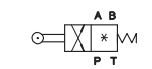
Valve model		DH-0	DK-1 (DK-12)	DP-2	DP-3
Max recommended flow	[l/min]	50	100 (140)	300	650
Max pressure on port P, A, B	[bar]	350	315	350	350
Max pressure on port T	[bar]		160		250

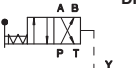
### 3 MAIN CHARACTERISTICS OF HAND & MECHANICAL OPERATED DIRECTIONAL VALVES

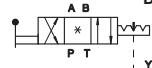
Assembly position / location	Any position.
Subplate surface finishing	Roughness index $\sqrt{0.4}$ , flatness ratio 0,01/100 (ISO 1101)
Ambient temperature	-20°C to + 70°C
Fluid	Hydraulic oil as per DIN 51524...535, for other fluids see section 1
Recommended viscosity	15 ÷ 100 mm <sup>2</sup> /s at 40°C (ISO VG 15 ÷ 100)
Fluid contamination class	ISO 19/16, achieved with in line filters at 25 µm value and β <sub>25</sub> ≥ 75 (recommended)
Fluid temperature	-20°C +60°C (standard and /WG seals) -20°C +80°C (/PE seals)

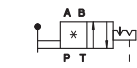
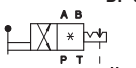
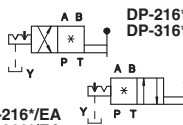
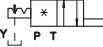
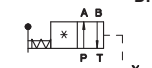
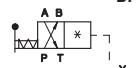
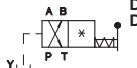
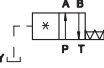
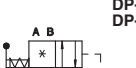
### 4 VALVE CONFIGURATION

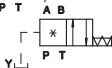
 DH-011* DK-111*	 DH-012* DK-112*	 DH-013* DK-113*	 DH-014* DK-114*	 DH-015* DK-115*
 DH-016*/I DK-116*/I	 DH-016*/E DK-116*/E	 DH-016*/IA DK-116*/IA   DH-016*/EA DK-116*/EA	 DH-017*/I DK-117*/I	 DH-017*/E DK-117*/E
 DH-017*/IA DK-117*/IA   DH-017*/EA DK-117*/EA	 DH-018*/I DK-118*/I	 DH-018*/E DK-118*/E	 DH-018*/IA DK-118*/IA   DH-018*/EA DK-118*/EA	
 DH-0230/2 DH-0231/2 DK-1230/2 DK-1231/2	 DH-0232/2 DK-1232/2	 DH-027* DK-127*	 DH-028* DK-128*	
 DP-211* DP-311*	 DP-212* DP-312*	 DP-213* DP-313*	 DP-214* DP-314*	 DP-215* DP-315*
 DP-216*/I DK-316*/I	 DP-216*/E DK-316*/E	 DP-216*/IA DK-316*/IA   DP-216*/EA DK-316*/EA	 DP-217*/I DK-317*/I	 DP-217*/E DK-317*/E
 DP-217*/IA DK-317*/IA   DP-217*/EA DK-317*/EA	 DP-218*/I DK-318*/I	 DP-218*/E DK-318*/E	 DP-218*/IA DK-318*/IA   DP-218*/EA DK-318*/EA	

- (1) Where the symbol doesn't show the hydraulic connection (\*), it depends by the central configuration of the spool, see table 5 .  
 (2) All the configuration shown for the lever operated valves are also available for valves actuated by mechanic without lever device.

### 5 SPOOLS - for intermediate passages, see tab. E001

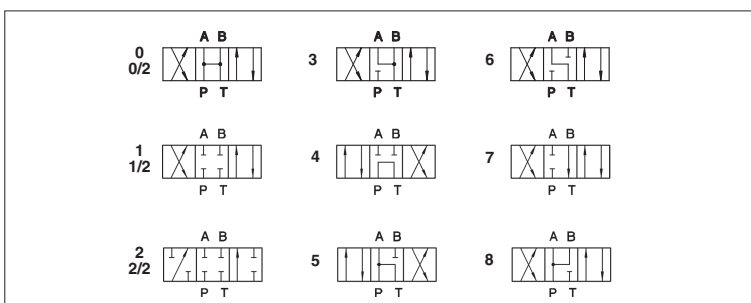

#### NOTES

- Spools type 0/2, 1/2, 2/2 are only used for valves type DH-023\*/2 and DK 123\*/2;
- Spools type 0 and 3 are also available as 0/1 and 3/1, where in centre position oil passage from ports to tank are restricted;
- Spools type 1,4 and 5 are also available as 1/1, 4/8 and 5/1. They are properly shaped to reduce water-hammer shocks during the switching;
- On request, other type of spools are available.

**6 DIMENSIONS OF HAND & MECHANICAL OPERATED VALVES ISO 4401 SIZE 06 [mm]**

**DH-00\*\***

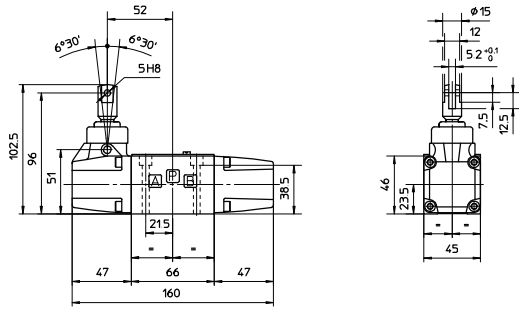

Mass: 1,2 Kg

**DH-02\*\***

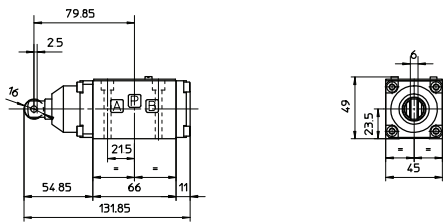

Working stroke: 2,5 mm; extra-stroke: 0,5 mm max. Mass: 1,2 Kg

**DH-01\*\***

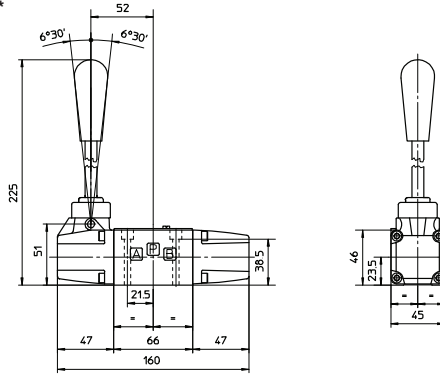

Mass: 1,6 Kg

**DH-01\*\*/C**

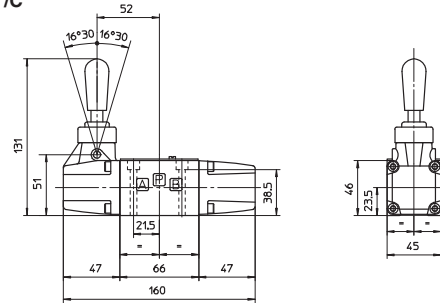

**ISO 4401: 2005**

**Mounting surface: 4401-03-02-0-05**

Fastening bolts: 4 socket head screws M5x50 class 12.9

Tightening torque = 8 Nm

Diameter of ports A, B, P, T: Ø = 7,5 mm (max)

Seals: 4 OR 108

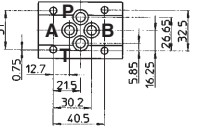

**P** = PRESSURE PORT  
**A, B** = USE PORT  
**T** = TANK PORT  
For the max pressures on ports, see section 2

Mounting subplates: see tab. E010

**7 DIMENSIONS OF HAND & MECHANICAL OPERATED VALVES ISO 4401 SIZE 10 [mm]**

**DK-10\*\***

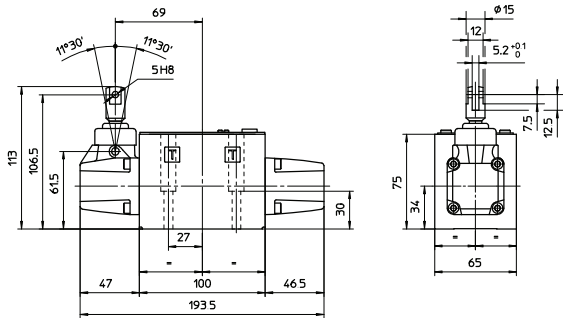

Mass: 2,5 Kg

**DK-11\*\***

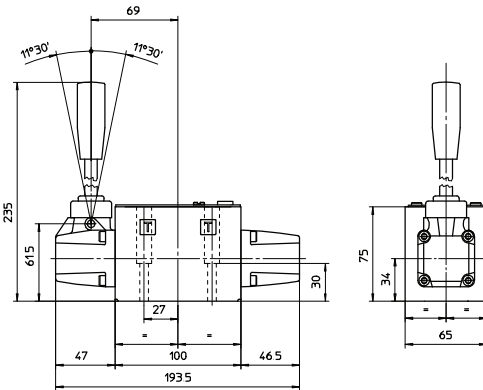

Mass: 2,8 Kg

**DK-12\*\***

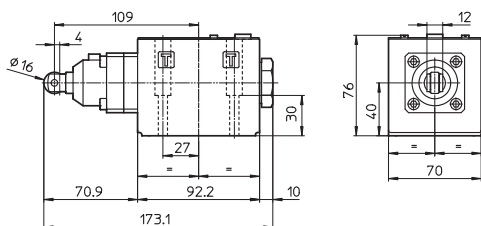

Working stroke: 4 mm; extra-stroke: 0,5 mm max. Mass: 2,5 Kg

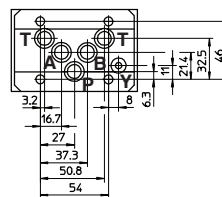

**P** = PRESSURE PORT  
**A, B** = USE PORT  
**T** = TANK PORT  
**Y** = DRAIN PORT  
For the max pressures on ports, see section 2

Note: port Y is normally plugged; for option /Y it must be connected separately and directly to tank

**ISO 4401: 2005**

**Mounting surface: 4401-05-05-0-05**

**(Without X port, Y port optional)**

Fastening bolts: 4 socket head screws M6x40 class 12.9

Tightening torque = 15 Nm

Diameter of ports A, B, P, T: Ø = 11,2 mm (max)

Seals: 5 OR 2050

Mounting subplates: see tab. E020

**8 DIMENSIONS OF HAND & MECHANICAL OPERATED VALVES ISO 4401 SIZE 16 [mm]**

**DP-20**

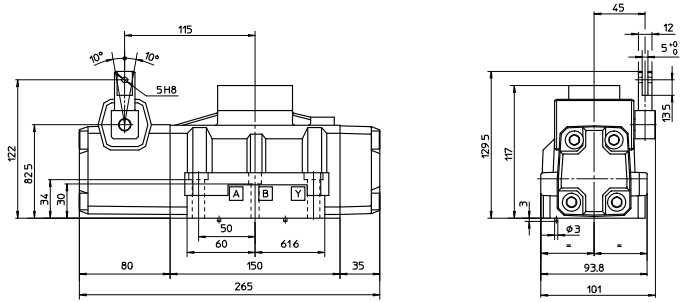

Mass: 9,7 Kg

**ISO 4401: 2005**

**Mounting surface: 4401-07-07-0-05**

Fastening bolts:

4 socket head screws M10x50 class 12.9

Tightening torque = 70 Nm

2 socket head screws M6x40 class 12.9

Tightening torque = 15 Nm

Diameter of ports A, B, P, T :  $\varnothing = 20$  mm

Diameter of ports X,Y:  $\varnothing = 7$  mm

Seals: 4 OR 130, 3 OR 109/70

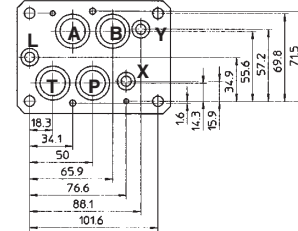

- P** = PRESSURE PORT
- A, B** = USE PORT
- T** = TANK PORT
- X** = EXTERNAL OIL PILOT PORT not used
- Y** = DRAIN PORT
- L** = DRAIN PORT FOR HYDRAULIC CENTERING DEVICE not used

For the max pressures on ports, see section 2

Note: ports X, L are not used.

Port Y for drain must be connected directly to tank.

No counter pressure are allowed on Y port.

**DP-21**

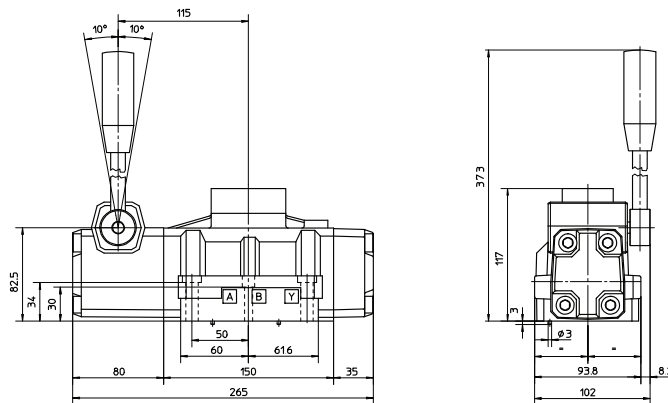

Mass: 10 Kg

Mounting subplates: see tab. E080

**9 DIMENSIONS OF HAND & MECHANICAL OPERATED VALVES ISO 4401 SIZE 25 [mm]**

**DP-30**

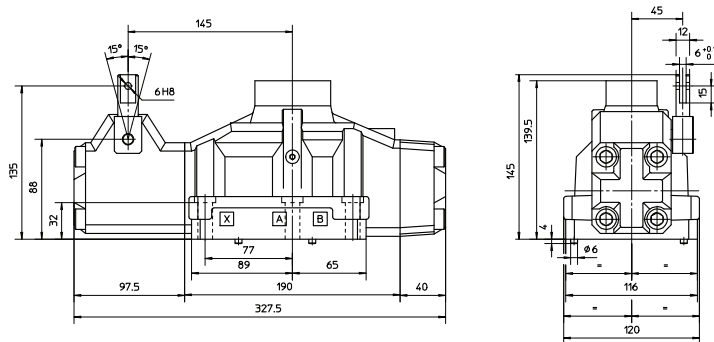

Mass: 15,2 Kg

**ISO 4401: 2005**

**Mounting surface: 4401-08-08-0-05**

Fastening bolts:

6 socket head screws M12x50 class 12.9

Tightening torque = 125 Nm

Diameter of ports A, B, P, T :  $\varnothing = 24$  mm

Diameter of ports X,Y:  $\varnothing = 7$  mm

Seals: 4 OR 4112, 3 OR 3056

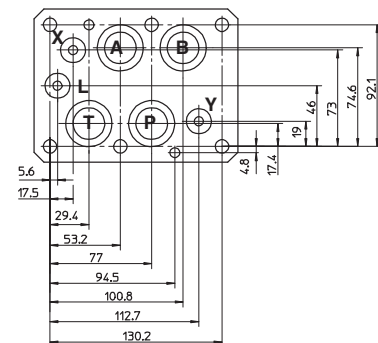

- P** = PRESSURE PORT
- A, B** = USE PORT
- T** = TANK PORT
- X** = EXTERNAL OIL PILOT PORT not used
- Y** = DRAIN PORT
- L** = DRAIN PORT FOR HYDRAULIC CENTERING DEVICE not used

For the max pressures on ports, see section 2

Note: ports X, L are not used.

Port Y for drain must be connected directly to tank.

No counter pressure are allowed on Y port.

**DP-31**

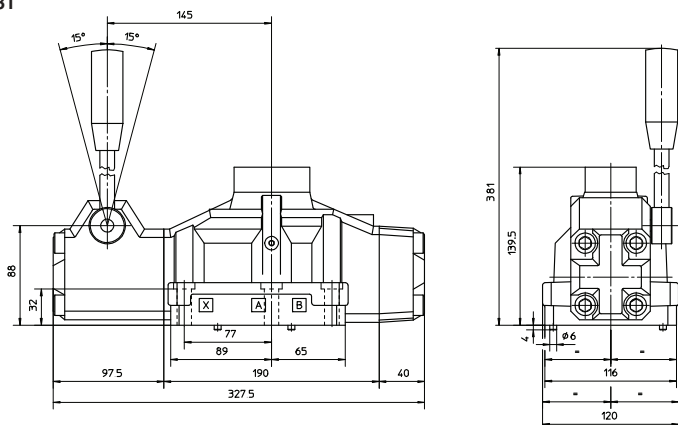

Mass: 15,5 Kg

Mounting subplates: see tab. E080